

**PARTS LIST**

**MODEL T-90**

**TANNER DE-ICER**



P.O. BOX 488, ST JOSEPH, MN 56374  
 PHONE: (320) 363-1800  
 TOLL-FREE: (800) 461-6454  
 FAX: (320) 363-1812

www.tannersystems.com  
 info@tannersystems.com

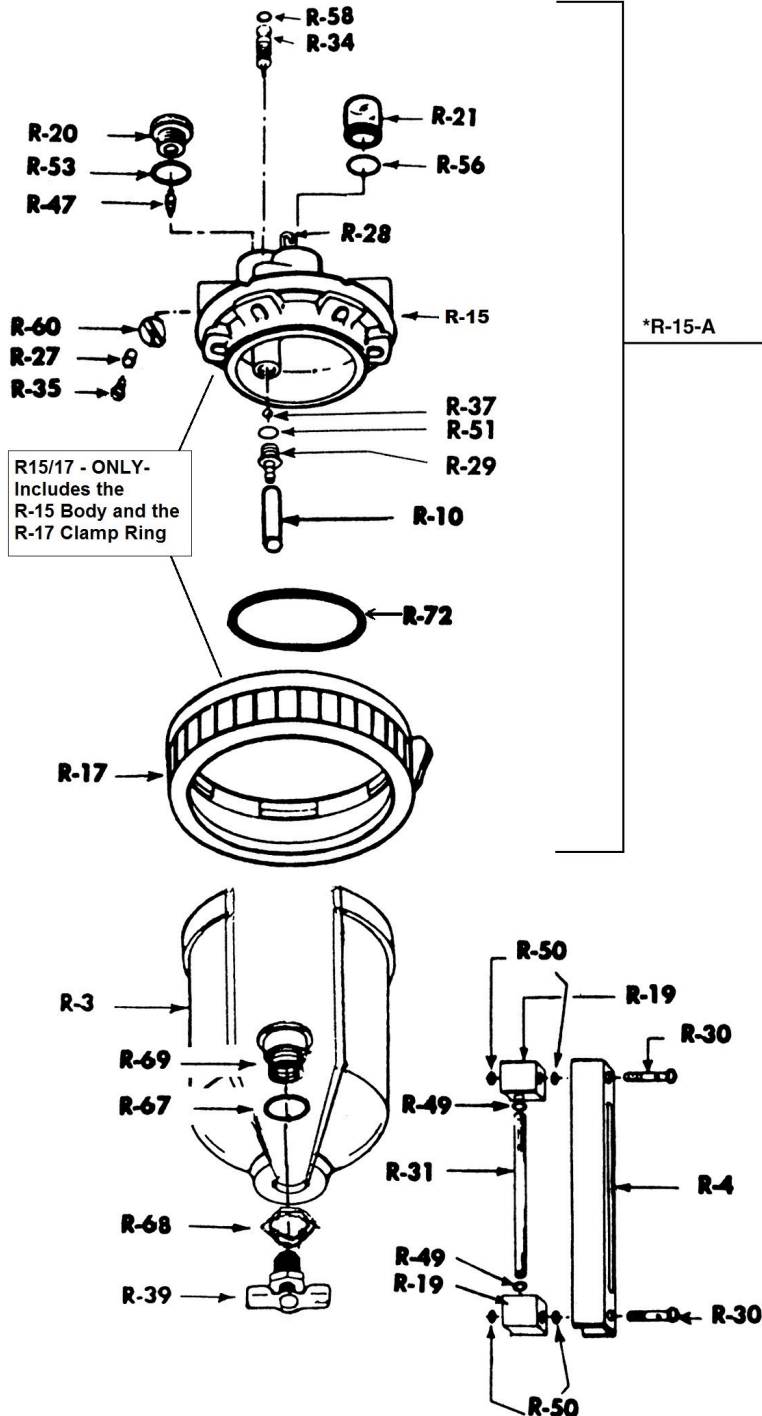

**IMPORTANT ... please order parts through one of our distributors.**

PART NO.	ITEM
R-58	O'Ring
R-34	Adjusting Screw
R-21	Sight Dome
R-56	O'Ring
R-20	Fill Plug
R-53	O'Ring
R-47	Check Valve
R-15/17	Body w/Clamp Ring, 3/4" inlet, outlet
R-28	Feed Tube
R-60	Flow Guide
R-27	Spacer
R-35	Flow Guide Screw
R-37	Ball Check
R-51	O'Ring
R-29	Adapter
R-10	Siphon Tube
R-72	O'Ring
R-3	Bowl, 1 Quart (NLA)
R-50	O'Ring (4)
R-19	Gauge Block (2)
R-30	Screw (2)
R-49	O'Ring (2)
R-31	Gauge Glass
R-4	Guard
R-67	O'Ring
R-68	Nut
R-69	Insert
R-39	Drain Cock
R-17	Clamp ring, Available only with R-15/17
R-26	Repair Kit (Not included With De-Icer) Consists of: 2 ea. R-58, R-49; 1 ea. R-34, R-21, R-56, R-20, R-53, R-47, R-60, R-35, R-29, R-72, R-37, R-51, R-27, R-67; 4 ea. R-50
R-66	Mounting Bracket Assembly (See Installation Form IN-1) OPTIONAL-NOT INCLUDED WITH DE-ICER
*R-15-A	Body Assembly

**-WARNING-**  
**MAX. WORKING PRESSURE: 200 p.s.i.**  
**MAX. INTERNAL AIR TEMP: 150° F**

# TANNER DE-ICER

## MODEL T-90

### INSTALLATION, FILLING AND OPERATING INSTRUCTIONS

1. Install De-Icer as close as possible to the problem area. Air must be less than 150°F at installation point.
2. If there is more than one freezing problem, install De-Icer at a point beyond the first receiver where all out-going air lines will be treated. ONLY install before the first receiver if ABSOLUTELY necessary to reach all problem areas.
3. **DO NOT** support the De-Icer by the hoses or pipe alone; the weight and movement could cause damage or cracking to the Body of the De-Icer. Install the De-Icer with air flowing in the direction indicated by the arrow on the Body, R-15/17.
4. Use only TANNERGAS<sup>®</sup>, FREEZE-BAN or NO-TOX2<sup>®</sup> fluid in this De-Icer. **DO NOT SMOKE WHILE FILLING.** This De-Icer may be filled under pressure by removing the Fill Plug, R-20, and pouring the fluid into the Bowl through the Fill Plug opening. NOTE: As the Fill Plug is removed, the air pressure in the Bowl is released; bleed air SLOWLY to prevent Fill Plug from disengaging under pressure. Be certain that air is completely bled before removing the Fill Plug. When filling is complete, re-install Fill Plug.
5. Allow several minutes for Bowl to fill with air. The rate of fluid delivery, TANNERGAS<sup>®</sup>, FREEZE-BAN or NO-TOX2<sup>®</sup>, may be controlled by turning the Adjusting Screw, R-34, counter clockwise for more, and clockwise for less, until desired fluid is dripping through Sight Dome, R-21. Do not open Adjusting Screw more than two turns.  
CAUTION: Do not remove Adjusting Screw when De-Icer is under pressure; be certain to adjust while there is air movement through the Body. This De-Icer delivers all the fluid downstream that passes through the Sight Dome. The fluid delivery rate will change automatically to deliver more during higher air flows and less for air flows lower than the original setting.

### MAINTENANCE

1. When TANNERGAS<sup>®</sup>, FREEZE-BAN or NO-TOX2<sup>®</sup> is not needed, close the Adjusting Screw, R-34; over-tightening may damage Adjusting Screw seat.
2. If contaminants in the Bowl, R-3, collect on the Siphon Tube, R-10, inlet filter, wash the filter in solvent.
3. Drain off any contaminants which collect in the bottom of the Bowl, using Drain Cock, R-39. Relieve pressure in Bowl prior to opening Drain Cock by slowly opening Fill Plug, R-20 (refer to above step 4).
4. Should it be necessary to disassemble this De-Icer for cleaning or repair, we recommend the Repair Kit, R-26, which contains all the O'Rings and other small replacement parts.

### WARRANTY

SELLER DISCLAIMS ANY AND ALL WARRANTIES UNLESS THIS DE-ICER IS USED EXCLUSIVELY WITH TANNERGAS<sup>®</sup>, FREEZE-BAN OR NOTOX2<sup>®</sup> AND ALL INSTRUCTIONS REGARDING INSTALLATION AND USE HAVE BEEN FOLLOWED.



P.O. BOX 488, ST JOSEPH, MN 56374

PHONE: (320) 363-1800  
TOLL-FREE: (800) 461-6454  
FAX: (320) 363-1812

www.tannersystems.com  
info@tannersystems.com

Printed in U.S.A.  
07/16